

BC3310

LITHIUM-POWERED BURDEN CARRIER

NEW



- Powerful lithium electric rear-wheel drive
- Onboard battery charger
- Built-in safety features
- Ideal for hard surfaces

 **snorkel**[™]

www.snorkellifts.com

LITHIUM-POWERED BURDEN CARRIER

BC3310

| DIMENSIONS | BC3310 |
|------------------------|-----------------------------|
| Overall Length (A) | 11' 3" (3.43m) |
| Overall Width (B) | 48" (1.21m) |
| Overall Height (C) | 59" (1.49m) |
| Carrier Bed Dimensions | 46" x 82.5" (1.16m x 2.09m) |
| Wheelbase | 64.5" (1.64m) |
| Ground Clearance | 4.6" (11.7cm) |

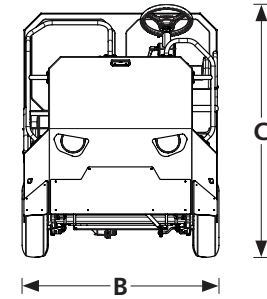
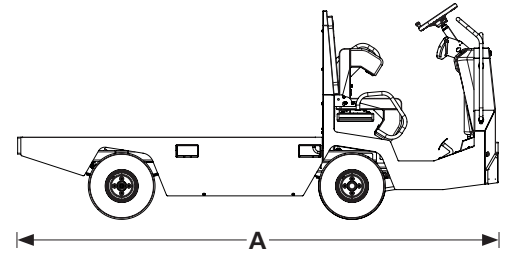

| PERFORMANCE | |
|----------------------------------|---------------------------------|
| Max. Cargo Load | 3,300 lbs (1,497kg) |
| Max. Tow Capacity | 10,000 lbs (4,536kg) |
| Max. Drive Speed (forward) | 15 mph (6.7m/s) |
| Max. Drive Speed (reverse) | 5 mph (2.2m/s) |
| Gradeability (Loaded / Unloaded) | 8% / 25% |
| Tires | 18.1" (46cm) foam-filled rubber |
| Controls | Steering Wheel |
| Drive System | Rear-wheel electric drive |
| Motor | Brushless DC |

| POWER | |
|--------------|-----------------------|
| Power Source | 48V Lithium batteries |
| Charger | 120–240V, 35 amp |

| WEIGHT | |
|--------|-------------------|
| Weight | 1,800 lbs (816kg) |

STANDARD FEATURES

- Seats two people
- Seated or standing drive positions
- 2-wheel drive
- Three speed settings
- Reverse alarm
- LED headlights
- Front safety strobes (x2)
- LED brake lights
- Hydraulic brakes—front & rear
- Automatic parking brake
- USB ports (x2)
- Onboard battery charger
- 2,000 charging cycles / 2-year** lithium battery warranty
- 2-year parts & labor warranty
- 5-year structural warranty

TURNING RADIUS

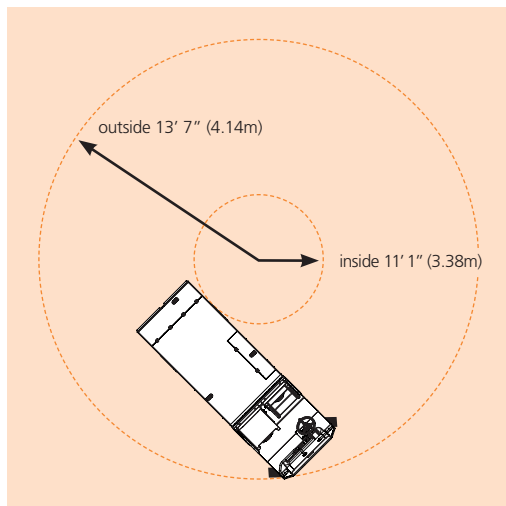

snorkel www.snorkellifts.com

P.O. Box 1160
 St. Joseph, MO 64502-1160, USA
 Tel: 1 (785) 989-3000
 Toll-Free: 1 (800) 255-0317
 Sales Fax: 1 (785) 989-3070
 Parts Fax: 1 (785) 989-3077
 Email: sales.usa@snorkellifts.com