

S9056RT-HC/S9070RT-HC

ULTRA-HIGH CAPACITY ROUGH TERRAIN SCISSOR LIFTS



- Ultra-high capacity, large deck rough terrain scissor lifts
- Excellent rough terrain performance
- Heavy duty design
- Dual powered extension decks
- Ideal for construction applications

 **snorkel**[™]
www.snorkellifts.com

ULTRA-HIGH CAPACITY ROUGH TERRAIN SCISSOR LIFTS

S9056RT-HC/ S9070RT-HC

DIMENSIONS	S9056RT-HC*	S9070RT-HC*
Max. working height	19.1m	23.3m
Max. platform height (A)	17.1m	21.3m
Platform size (stowed)	2.28m x 4.87m	
Platform size (dual deck extended)	2.28m x 8.23m	
Extension deck length	1.37m	1.37m
Overall width (B)	2.28m	2.28m
Overall length (C)	4.87m	4.87m
Stowed height (D)	3.09m	3.43m
Min. height (guardrails folded)	2.1m	2.5m
Ground clearance	356mm	356mm

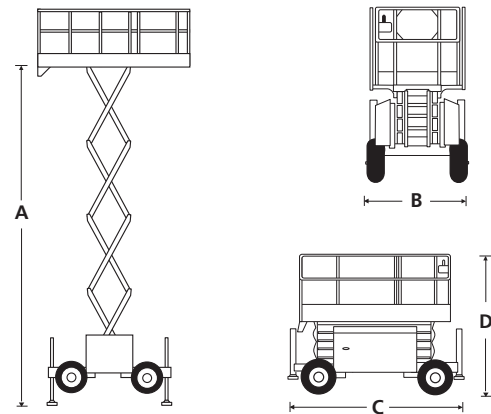

PERFORMANCE	S9056RT-HC*	S9070RT-HC*
Platform capacity (SWL)	1,134kg	907kg
Max. drive height	13.1m	13.1m
Max. wind speed	12.5m/s	12.5m/s
Max. drive speed (stowed)	6.7km/h	6.7km/h
Max. drive speed (elevated)	0.96km/h	0.96km/h
Raise/lower time	55/35 sec	70/40 sec
Gradeability	50%	50%
Max. stabilizer levelling, front to rear	6°	6°
Max. stabilizer levelling, side to side	12°	12°
Inside turning radius	2.4m	2.4m
Outside turning radius	5.6m	5.6m
Tires	13 x 36 foam filled	
Controls	proportional joystick	
Drive system	4-wheel drive	

POWER	S9056RT-HC*	S9070RT-HC*
Power source	Kubota diesel	

WEIGHT	S9056RT-HC*	S9070RT-HC*
Weight	9,072kg	11,566kg

TURNING RADIUS

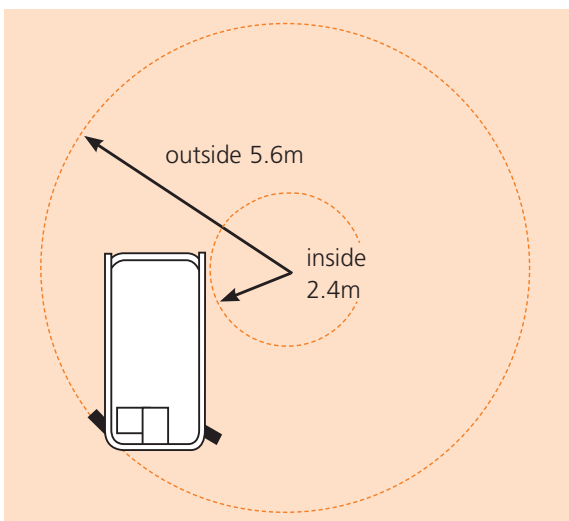

ANSI Specification
© Snorkel 2021

Specifications subject to change without notice. Photos and diagrams in this brochure are for promotional purposes only. Refer to appropriate Snorkel operators manual for detailed instructions on the proper use and maintenance.
*Preliminary specifications – confirm at time of ordering.

STANDARD FEATURES

- 4-wheel drive
- 4 hydraulic stabilizers with automatic levelling
- Dual powered extension decks
- Proportional controls
- Foam filled tires
- Power line to platform
- Platform overload system
- Drive motion alarm
- Descent alarm
- Locking, oscillating axle
- Fold-down guardrails
- Manual lowering valve
- Flashing amber light (x2)
- Dual lanyard attachment points
- Hour meter & on-board diagnostics display
- 2 year parts & labor, 5 year structural warranty
- ANSI compliant

OPTIONS

- Special paint colors
- Nylon spreader pads (set of 4)
- Environmental hydraulic oil
- Non-marking foam filled tires
- Cold weather package (block heater + battery warm up)
- Hydraulic generator 110V 2kW
- 12kW generator package

snorkel www.snorkellifts.com

P.O. Box 1160
St. Joseph, MO 64502-1160, USA
Tel: 1 (785) 989-3000
Toll-free: 1 (800) 255-0317
Fax: 1 (785) 989-3070
Email: sales.usa@snorkellifts.com

02/2021