

# S9056RT-HC/S9070RT-HC

ULTRA-HIGH CAPACITY ROUGH TERRAIN SCISSOR LIFTS



- Ultra-high capacity, large deck rough terrain scissor lifts
- Excellent rough terrain performance
- Heavy duty design
- Dual powered extension decks
- Ideal for construction applications

 **snorkel**™  
[www.snorkellifts.com](http://www.snorkellifts.com)

# ULTRA-HIGH CAPACITY ROUGH TERRAIN SCISSOR LIFTS

# S9056RT-HC/ S9070RT-HC

DIMENSIONS	S9056RT-HC*	S9070RT-HC*
Max. working height	62 ft	76 ft
Max. platform height (A)	56 ft	70 ft
Platform size (stowed)	16 ft x 7 ft 6 in	
Platform size (extended)	27 ft x 7 ft 6 in	
Extension deck length	4 ft 6 in	4 ft 6 in
Overall width (B)	7 ft 6 in	7 ft 6 in
Overall length (C)	16 ft	16 ft
Stowed height (D)	10 ft 2 in	11 ft 3 in
Min. height (guardrails folded)	7 ft	8 ft 5 in
Ground clearance	14 in	14 in

PERFORMANCE	S9056RT-HC*	S9070RT-HC*
Platform capacity (SWL)	2,500 lbs	2,000 lbs
Max. drive height	43 ft	43 ft
Max. wind speed	28 mph	28 mph
Max. drive speed (stowed)	4.2 mph	4.2 mph
Max. drive speed (elevated)	0.6 mph	0.6 mph
Raise/lower time	55/35 sec	70/40 sec
Gradeability	50%	50%
Max. stabilizer levelling, front to rear	6°	6°
Max. stabilizer levelling, side to side	12°	12°
Inside turning radius	8 ft	8 ft
Outside turning radius	18 ft 6 in	18 ft 6 in
Tires	13 x 36 foam filled	
Controls	proportional joystick	
Drive system	4-wheel drive	

POWER	S9056RT-HC*	S9070RT-HC*
Power source	Kubota diesel	

WEIGHT	S9056RT-HC*	S9070RT-HC*
Weight	20,000 lbs	25,500 lbs

## TURNING RADIUS

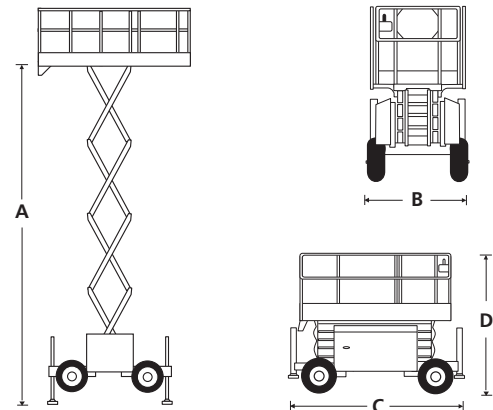
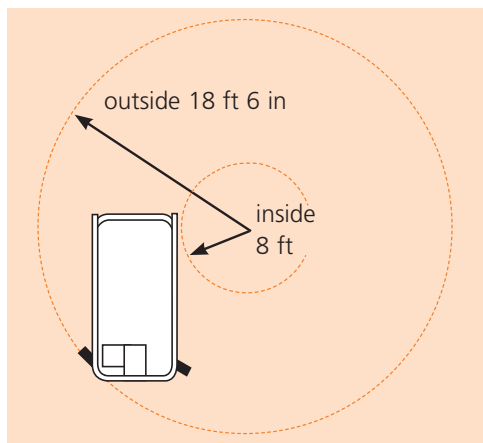

## STANDARD FEATURES

- 4-wheel drive
- 4 hydraulic stabilizers with automatic levelling
- Dual powered extension decks
- Proportional controls
- Foam filled tires
- Power line to platform
- Platform overload system
- Drive motion alarm
- Descent alarm
- Locking, oscillating axle
- Fold-down guardrails
- Manual lowering valve
- Flashing amber light (x2)
- Dual lanyard attachment points
- Hour meter & on-board diagnostics display
- 2 year parts & labor, 5 year structural warranty
- ANSI compliant

## OPTIONS

- Special paint colors
- Nylon spreader pads (set of 4)
- Environmental hydraulic oil
- Dual fuel
- Non-marking foam filled tires
- Cold weather package (block heater + battery warm up)
- Hydraulic 110V 2kW generator
- 12kW generator package

**snorkel** [www.snorkellifts.com](http://www.snorkellifts.com)

P.O. Box 1160  
St. Joseph, MO 64502-1160, USA  
Tel: 1 (785) 989-3000  
Toll-free: 1 (800) 255-0317  
Fax: 1 (785) 989-3070  
Email: sales.usa@snorkellifts.com