

600AJN

ARTICULATED BOOM LIFT



- Fully electric, with dual fuel regeneration for extended duty cycles per charge
- Zero emissions with quiet operation for indoor use
- Can be fully recharged in 6 hours
- Gravity-descent design to maximize efficiency and duty cycle
- Zero tailswing and zero steer for maximum maneuverability

 **snorkel**[™]
www.snorkellifts.com

ARTICULATED BOOM LIFT

600AJN

| DIMENSIONS | 600AJN* |
|-----------------------------------|-------------|
| Max. working height | 66 ft 2 in |
| Max. platform height | 60 ft 2 in |
| Max. horizontal reach | 44 ft 6 in |
| Clearance height at max. outreach | 21 ft 6 in |
| Platform size | 6 ft x 3 ft |
| Overall width (A) | 7 ft |
| Overall length (B) | 30 ft 4 in |
| Stowed height (C) | 7 ft 6 in |
| Ground clearance | 9.75 in |

| PERFORMANCE | |
|----------------------------------|-----------------------------|
| Platform capacity (restricted) | 1,000 lbs |
| Platform capacity (restricted 2) | 600 lbs |
| Platform capacity (unrestricted) | 350 lbs |
| Max. drive height | 60 ft 2 in |
| Max. wind speed | 28 mph |
| Max. drive speed (stowed) | 4.25 mph |
| Max. drive speed (elevated) | 0.6 mph |
| Jib length | 5 ft 5 in |
| Jib working arc | 75° |
| Platform rotation | 180° |
| Superstructure rotation | 360° continuous |
| Tailswing | 0 in |
| Foreswing | 12 in |
| Raise/lower time | 80/80 sec |
| Gradeability | 45% |
| Inside turning radius | 5 ft 6 in |
| Outside turning radius | 11 ft |
| Oscillating axle | 8 in |
| Tires | 33 x 10-24 foam filled |
| Controls | fully proportional |
| Drive system | 48V electric, 4-wheel drive |

| POWER | |
|--------------|---|
| Power source | 48V DC batteries (8 x 6v) Kubota WG752 17.2hp dual fuel (gasoline/LPG) Tier 3 powering 6kW DC generator |

| WEIGHT | |
|--------|------------|
| Weight | 26,500 lbs |

WORKING ENVELOPE

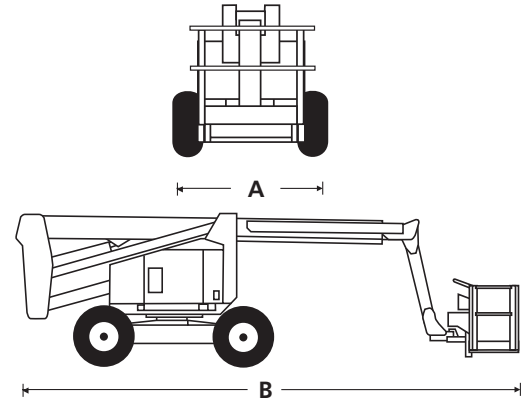
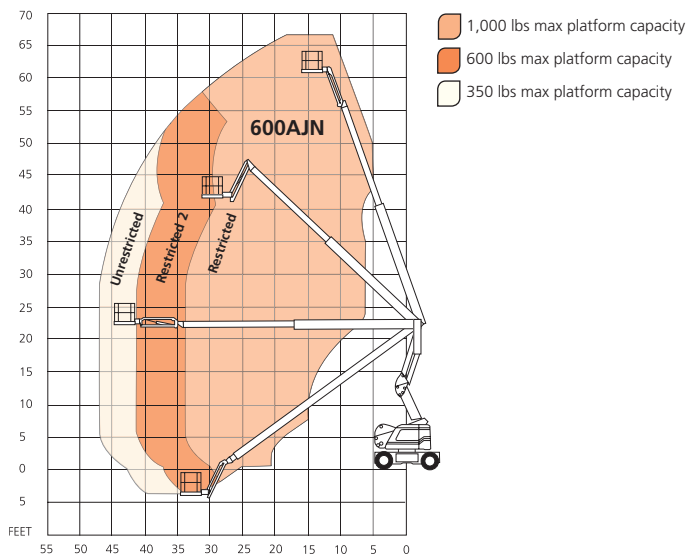

STANDARD FEATURES

- Zero tailswing
- 4 steering modes - 2-wheel, 4-wheel, crab, and pivot
- Snorkel Guard™ secondary guarding system
- Proportional controls
- Oscillating axle
- 6' tri-entry platform with high grip aluminum floor
- Foam filled tires
- Power line to platform
- Hour meter & on-board diagnostics display
- Tilt alarm
- Horn
- Battery charge indicator
- Drive motion alarm
- Flashing amber light
- 2 year parts & labor, 5 year structural warranty
- ANSI compliant

OPTIONS

- Special paint colors
- Airline to platform
- Non-marking tires
- 12V cooling fans in platform
- Mesh platform guarding
- Tool tray
- Folding workbench in platform
- Aircraft package
- Deluxe aircraft package
- Cold weather package
- Extreme cold weather package
- Extreme environment package
- Light package
- Utility package
- Glazier package
- Pipe rack
- Generator package 2.5kW
- Generator package 6kW
- Environmental hydraulic oil

snorkel www.snorkellifts.com

P.O. Box 1160
 St. Joseph, MO 64502-1160, USA
 Tel: 1 (785) 989-3000
 Toll-Free: 1 (800) 255-0317
 Sales Fax: 1 (785) 989-3070
 Parts Fax: 1 (785) 989-3077